

# State of Wyoming Corner Record

(In compliance with the **CORNER PERPETUATION AND FILING ACT**, Wyoming Statutes, 1997 Section 33-29-140 et. seq., and the Rules and Regulations of the Board of Professional Engineers and Professional Land Surveyors)

Reverse side of this form may be used if more space is needed.

Record of original survey and citation of source of historical information (if corner is lost or obliterated). Description of corner monumentation evidence found and/or monument and accessories established to perpetuate the location of this corner. Sketch of relative location of monument, accessories, and reference points with course and distance to adjacent corner(s) (if determined in this survey). Method and rationale for reestablishment of lost or obliterated corner.

GLO RECORD: "SET AN IRON POST, 3 FT. LONG, 1 INCH DIAM., 2 1/2 FT. IN THE GROUND, FOR 1/4 SEC. COR., AND MARK ON THE BRASS CAP ON THE POST."

MONUMENT FOUND: FOUND 1" PIPE WITH 2 1/2" BRASS CAP STAMPED U.S. GLO 1911 AS SHOWN BELOW, MONUMENT WAS DISTURBED AND BADLY BENT TO THE EAST, DUGOUT AND SPUN MONUMENT TO FIND BASE. MONUMENT WAS RECOVERED FLUSH WITH NATURAL GROUND SURFACE AND INLINE WITH A FENCE TO THE SOUTH.

MONUMENT SET: SET #6 REBAR WITH 2 1/2" ALUMINUM CAP STAMPED LS 4522 AND 2010 AS SHOWN BELOW, SET AT THE BASE OF AND ON THE WEST SIDE OF FOUND GLO MONUMENT, 0.2'± BELOW NATURAL GROUND SURFACE.

REFERENCES: FOUND AND OR SET REFERENCE TIES AS SHOWN IN SKETCH BELOW.

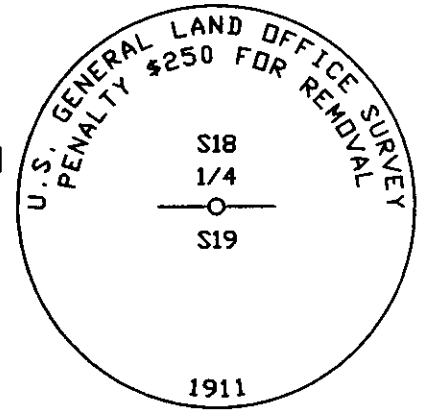
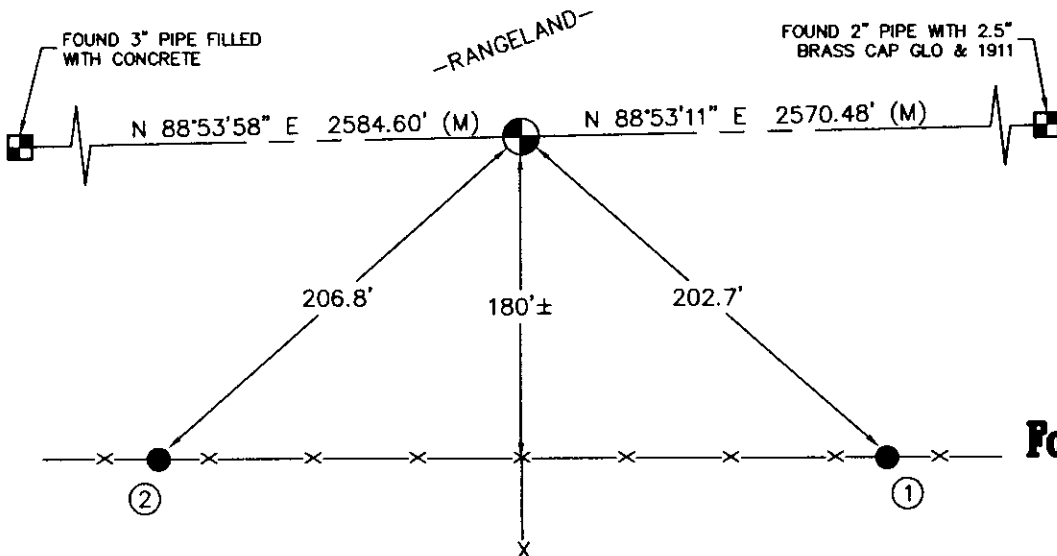

**Found Monument Inscription**

RECORDED 7/13/2010 AT 8:22 AM REC# 548556 X# 2173 PG# 434  
DEBRA K. LATHROP, CLERK OF LARAMIE COUNTY, WY PAGE 1 OF 1

- ① SET #4 X 12" REBAR IN FENCE LINE.
- ② SET #4 X 12" REBAR IN FENCE LINE.

\*NOTE: THE BEARINGS LISTED HEREON ARE GRID BEARINGS OF THE WYOMING COORDINATE SYSTEM NAD 1983, EAST ZONE.



NOT TO SCALE

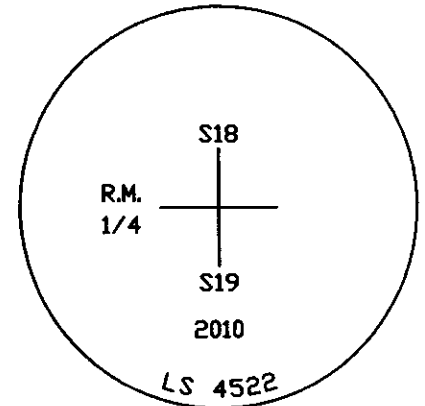

**Set Monument Inscription**

L10-13

Date of Field Work: 5/14/10

Office Reference: 2010022 (LAT40)

## Cross Index Plat

	1	2	3	4	5	6	7	8	9	10	11	12	13	14	15	16	17	18	19	20	21	22	23	24	25		
A																											A
B																											B
C			6		5			4					3					2							1		C
D																											D
E																											E
F																											F
G																											G
H																											H
J																											J
K																											K
L																											L
M																											M
N																											N
O																											O
P																											P
Q																											Q
R																											R
S																											S
T																											T
U																											U
V																											V
W																											W
X																											X
Y																											Y
Z																											Z

Firm/Agency, Address

Lambert Land Consulting, LLC  
417 South Whitcomb Street  
Fort Collins, Colorado 80521

Telephone Number: 970-217-2190

This corner record was prepared by me or under my direction and supervision.

SEAL & SIGNATURE

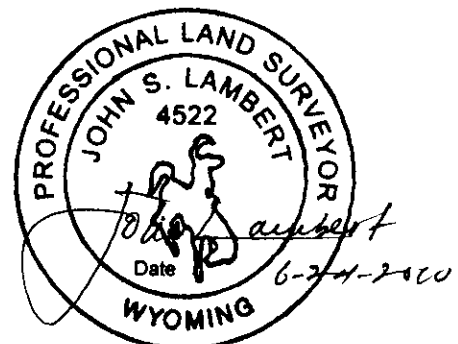

Corner Name SOUTH 1/4 Corner Section 18, T 12 N, R 62 W, 6th P.M.  
County: LARAMIE Wyoming

Cross-Index No.: N-3